



FORTRESS[®]

FASTENERS

Product Catalogue
Builders Hardware

www.fortress.kiwi

msl
manufacturing suppliers ltd.

Fortress Catalogues Now Available

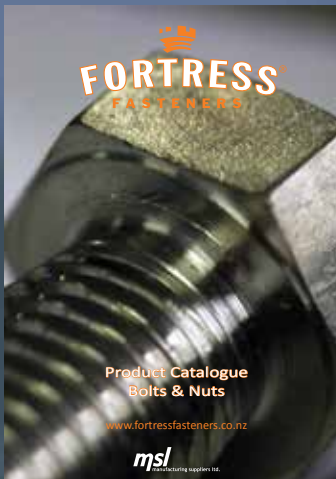

Bolts & Nuts

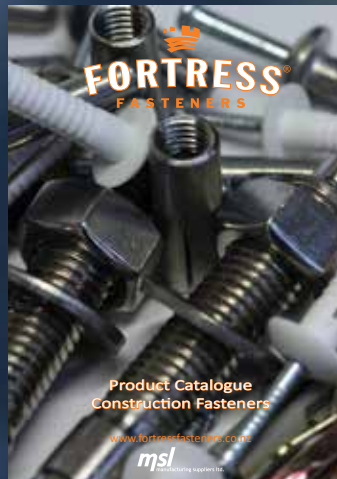

Construction Fasteners

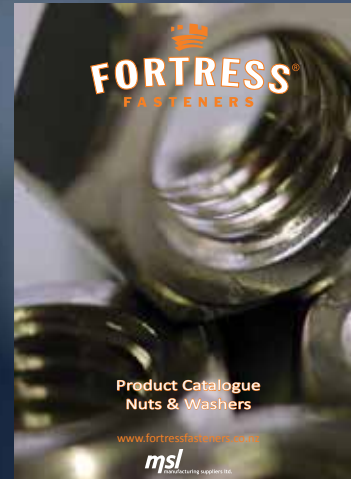

Nuts & Washers

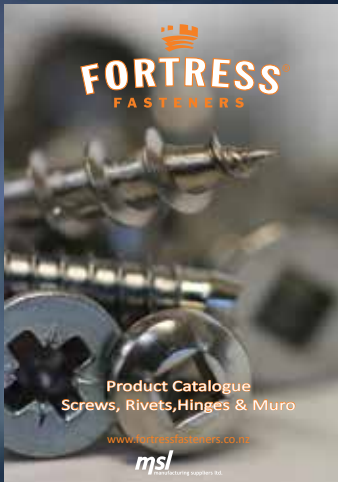

Screws, Rivets, Hinges & Muro

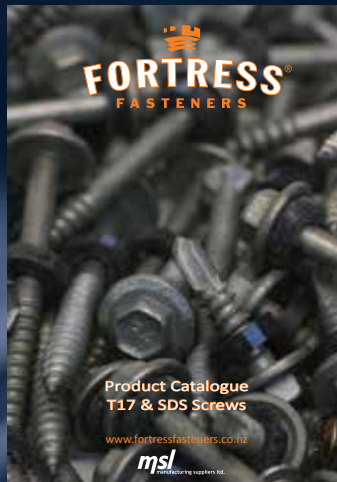

T17 & SDS Screws

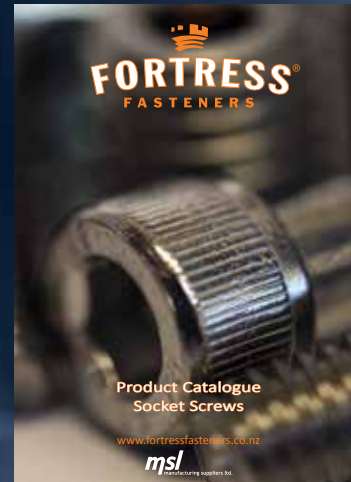

Socket Screws



Muro - Only available online.



Builders hardware



FORTRESS[®]
FASTENERS

Fortress is a quality New Zealand brand conceived and distributed by MSL.

Manufacturing Suppliers Ltd (MSL) was the innovation of the company founder in 1980, starting as a small operation in New Lynn, Auckland. It was his vision to meet industry demands for a range of quality fasteners backed by a dependable service. 35 years on, this vision is still paramount, a service that delivers a range of fasteners on time, every time.

We have grown dramatically since the eighties with nine branches nationwide. Now, as part of the Steel & Tube Group we remain 100% New Zealand owned and operated and we continue to pride ourselves on our personal service.

Today we employ over one hundred people and have a network of fully-stocked branches carrying over 330 million items and 17,000 product lines. This makes us arguably the largest fastening wholesaler in the country. Our new products, creative packaging and merchandising initiatives have also earned us a reputation as industry innovators.

We owe our success to our ability to deliver on time and in full to a wide customer base in manufacturing industries, the building trade and to building supplies merchants in New Zealand.

This, combined with the strength of our own Fortress brand and our exceptional customer service is what makes MSL a market leader.

Our ownership means we understand the local market and have the ability to make decisions rapidly and easily. Large enough to meet the demands of any customer, we are still small enough to offer the personal touch.

Auckland (Head Office)

560 Rosebank Road, Avondale
Phone 09 828 2777
Fax 09 828 2424

Albany

Unit 4, 4 William Pickering Drive
Phone 09 414 7620
Fax 09 414 7410

Hamilton

51 Vickery Street, Te Rapa
Phone 07 850 8434
Fax 07 850 5696

Mount Maunganui

7 Newton Street
Phone 07 575 0508
Fax 07 575 0557

Hastings

199 St. Aubyn Street West
Phone 06 873 3311
Fax 06 873 3315

New Plymouth

25 Hurlstone Drive, Waiwhakaiho
Phone 06 8248950 or 06 8248951
Fax 06 7574391

Palmerston North

94 Kaimanawa Street
Phone 06 355 5990
Fax 06 355 5880

Wellington

6 Regent Street, Petone
Phone 04 586 2300
Fax 04 586 2600

Christchurch

66 Hammersmith Drive, Sockburn
Phone 03 343 6740
Fax 03 343 6741



BUILDERS HARDWARE

- Producer Statements	Page 06
- Exposure Guide	Page 08
- Durability Guide	Page 11
- Ultimate Brick Ties	Page 12
- Bracing Bracket Kits	Page 13
- Nail Plates	Page 14
- 6 kN pile Fixing Kits	Page 14
- 12 kN Pile Fixing Kits	Page 15
- Cleats	Page 16
- Z Nails	Page 16
- Annular Groved Nails	Page 17
- Brace Strapping	Page 17
- Sheet Brace Strapping	Page 17
- Multi Grips	Page 18
- Diagonal Cleats	Page 18
- Building Paper Grippers	Page 18
- Cyclone Ties	Page 19
- Ceiling Hangers	Page 19
- CT160 Cleats	Page 19
- CPC, 6kN & 16kN CPC Truss Kits	Page 19
- Girt Plates	Page 20
- Stud Strap	Page 21
- Joist Hangers	Page 21
- Joist Grippa	Page 21
- Product Substitutions	Page 22
- Product Codes	Page 23

Fortress Builders Hardware producer statement.

This Producer statement has been prepared by MSL Fortress Fasteners to cover the purpose, installation procedure and durability of FORTRESS BUILDERS HARDWARE as required by the New Zealand Building Code.

All Fortress Builders hardware is Z275 Galvanised or T304/T316 Stainless steel for use in any situation - internal or external construction.

Each Fortress Builders Hardware product is primarily designed for timber to timber construction but also specific materials such as masonry and steel depending on the products purpose. Please contact Fortress or refer to installation instructions should you require any assistance with determining the correct application for our products.

Storage of Fortress Builders Hardware prior to use should be in a dry, moisture free environment that will not affect the durability of the product. There should be no damage or wear to the product surface at the time of installation.

The durability of the Fortress Builders Hardware range is in accordance with the acceptable solutions contained in NZS3604:2011. All product drawings and specifications have been independently reviewed to ensure they meet full specification at pre-manufacturing stage.

Nail Plates

Designed for use with a range of structural and non-structural timber applications. For joining timber. A very positive resistance is created when hammering nails, making it very hard to withdraw.

Brace Strapping

Fortress Multi-purpose strapping is the solution to maintain rigidity in horizontal and vertical lines in framing, carports, pergolas, roofing, walls, ceilings, floors, etc. Easy to attach and tension.

Joist Hangers

Designed to fix joist, beams, truss, rafters and purlins where a sturdy joint is required. Available in Z275 Galvanised and T304 Stainless Steel.

Z & C Nails

Available in left hand, right hand and straight configurations. Effective way to fix purlins, rafters, joists and beams. Creates a strong, low cost, wind resistant fixture.

Multigrips

Multi-purpose plate that can be used left or right hand and fastened with annular grooved nails. With the ability to be bent on-site to any required shape, the multigrip can secure timber connections across multiple planes.

Cyclone Straps

Designed for timber construction in high-wind risk areas. Bent over and under timber where required, they are applicable for many positions.

6kN Pile Bearer Kits

Suitable for fixing cantilever timber piles to bearers.

Subfloor construction must be in accordance with NZS3604:2011 Reference 6.7.3 – Bearer fixings to cantilever piles. For use on timber joists and bearers up to 150mm deep. The fixings provided in this kit must be applied in accordance with the directions included with the product.

Externally tested by SGS New Zealand Ltd.

12kN Pile Bearer Kits

Suitable for fixing of timber piles.

This kit must be installed in accordance with the information supplied to meet NZS3604: 2011 standards. Lines of lateral support to floor joists as specified in 7.1.2.2 of the above standard shall be provided within 300mm of the ground floor, sub-floor lines and along other lines of the ground floor that contain bracing element.

Externally tested by SGS New Zealand Ltd.

Sheet Bracing Strap

Complies with 3604:2011.

Easy to install brace strapping to provide 6kN or 12kN hold down strength.

Building Paper Grippers

Available in strips of 5. A quick and easy way to fasten building paper, shade cloth and plastic sheeting. Reduces tearing.

Girt Plates

Designed to fix girt to pole. Pre-folded and cut for wrapping if required.

CPC Truss Kits 9kN and 16kN

Concealed Purlin Cleat kits are perfect for use with exposed timber. Will resist any uplift due to wind. Supplied with annular grooved nails and T17 screws.

Diagonal Cleats

Folded nail-on-plate.

Can be used for fixing girts and purlins to rafters in high wind zones.

Provides a strong 90° butt joint for large timber sizes.

Available in left and right hand.

Ceiling Hangers

Used to fix ceiling joists to rafters or trusses. Can be used in a variety of building situations.

Available in left and right hand.

Bracing Bracket

The Fortress Bracing Bracket has been engineered to offer premium support with most quality panel hold down bracing elements. Offering speedy installation, the Fortress Bracing Bracket requires little effort to install accurately. For use in both external and internal bracing elements.

Exceeds NZS 3604:2011 guidelines.

The Ultimate Brick Tie

Used in brick veneer construction, rated Earthquake Heavy and clearly stamped EH. The only brick tie that meets NZS 2699.1.2000. Superior grip tension on all planes of movement. 50 year Durability Warranty. New Galvanising technology offers 70+ microns.

Stud Strap

This pre-bent strap is fastened to the face of the stud and over the top plate. It creates an effective and quick solution. Avoids plastering over internal fixings, as only one per stud is required.

The Fortress Builders Hardware catalogue is current at the time of printing. The range may be updated or expanded following print. Talk to your Fortress account manager for further information.

NEW ZEALAND EXPOSURE ZONES



©Copyright Standards New Zealand. Fig 4.2 from NZS 3604:2011 has been granted permission by Standards New Zealand under licence 001124.

NEW ZEALAND EXPOSURE ZONES

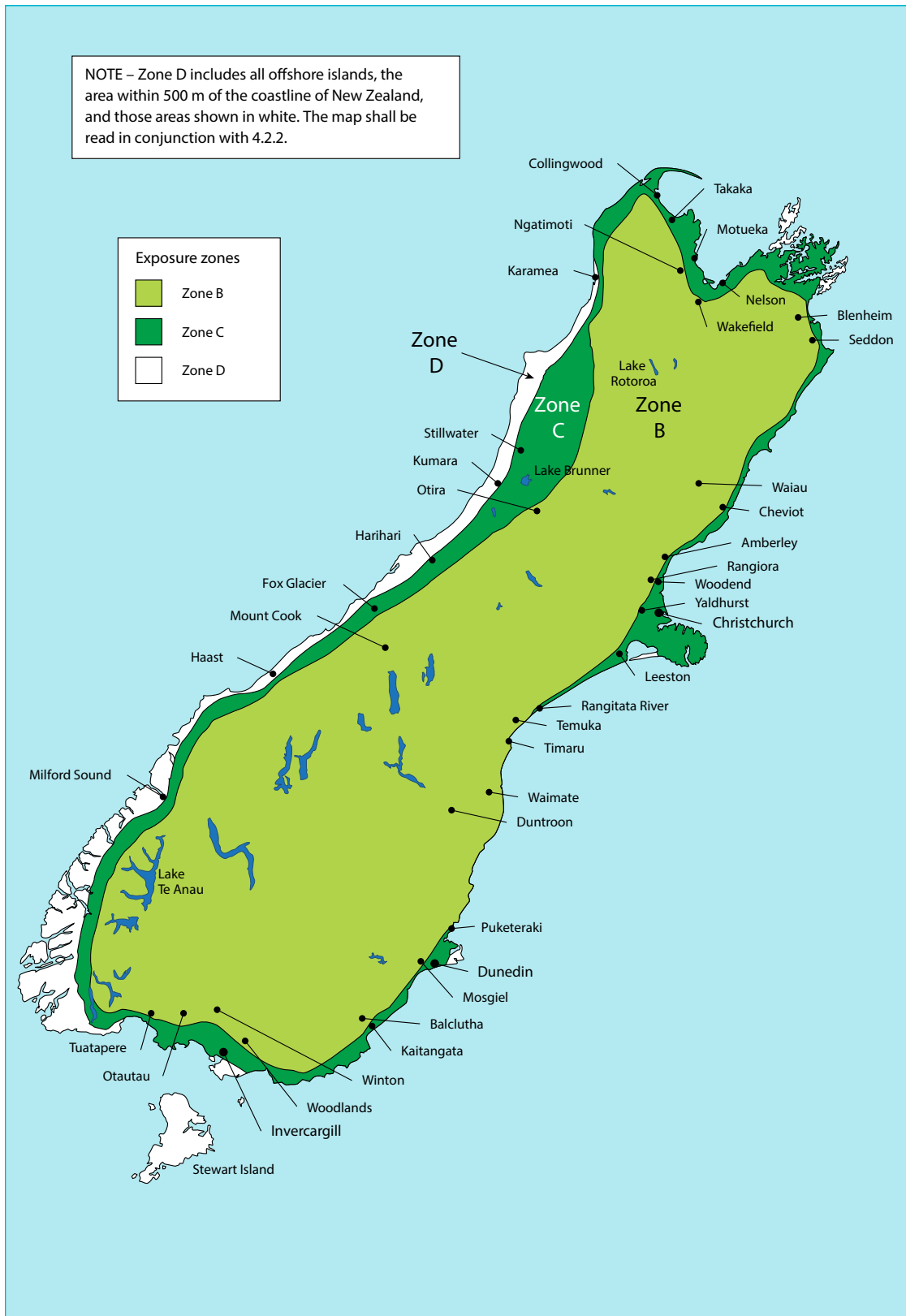

©Copyright Standards New Zealand. Fig 4.2(continued) from NZS 3604:2011 has been granted permission by Standards New Zealand under licence 001124.

RESIDENTIAL EXPOSURE GUIDE

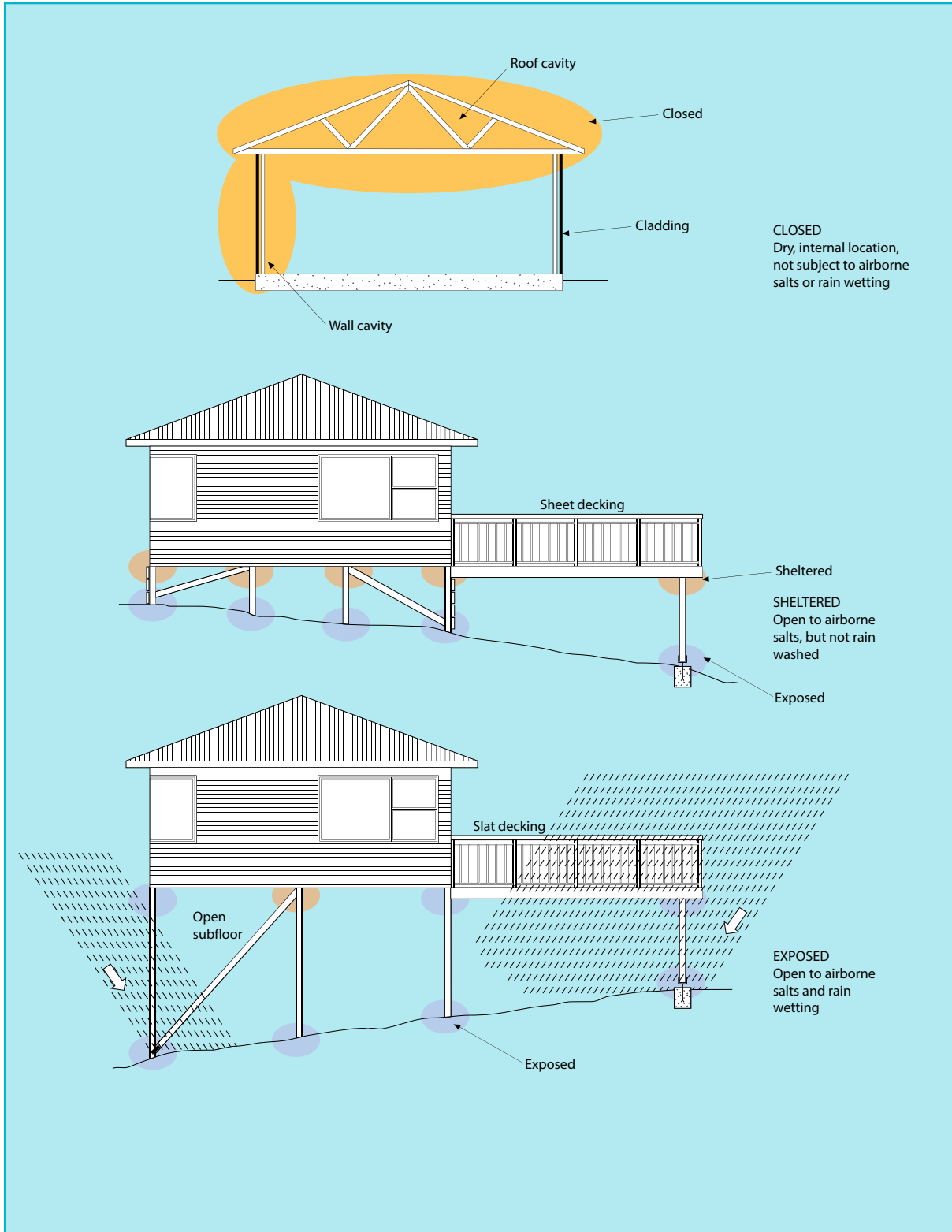

©Copyright Standards New Zealand. Fig 4.2 from NZS 3604:2011 has been granted permission by Standards New Zealand under licence 001124.

DURABILITY GUIDE

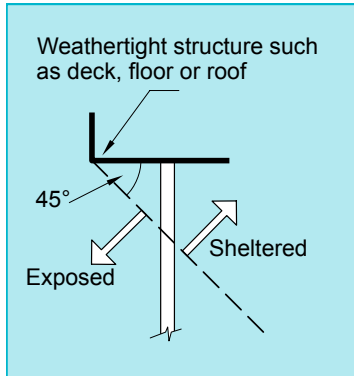

ZONES	FIXING FASTENING	ENVIRONMENT		MATERIAL
ALL ZONES	Nail plates	CLOSED AND ROOF SPACES		Continuously coated galvanized steel ⁽²⁾
	Wire dogs & bolts			Hot-dipped galvanized steel ⁽²⁾
	All other structural fixings	CLOSED		Mild steel (uncoated, non-galvanized) ⁽³⁾
ZONE D	All structural fixings	SHELTERED ⁽⁴⁾ AND EXPOSED		Type 304 stainless steel ⁽⁵⁾
ZONES B AND C	Treated timber pile connections more than 600 mm from the ground and all subfloor connections	Subfloors vented 7000 mm ² or less	SHELTERED ⁽⁴⁾	Hot-dipped galvanized steel ⁽²⁾
		Subfloors vented more than 7000 mm ²	EXPOSED	Type 304 stainless steel ⁽⁵⁾
	Treated timber pile connections within 600 mm of the ground	SHELTERED ⁽⁴⁾ AND EXPOSED		Type 304 stainless steel ⁽⁵⁾
	All other structural fixings, except fabricated brackets ⁽⁶⁾	SHELTERED ⁽⁴⁾		Hot-dipped galvanized steel ⁽²⁾
EXPOSED		Type 304 stainless steel ⁽⁵⁾		

- (1) Items described in this table are steel fasteners required to last not less than 50 years, used for joining timber, such as nail plates, bolts, brackets, wire dogs and similar, but not including nails or screws (which are described in table 4.3).
- (2) All galvanizing weights to steel shall be as given in table 4.2.
- (3) Steel fixings in timber treated with copper-based timber preservatives shall be as per 4.4.4.
- (4) "Sheltered" shall be that above a 45° line drawn from the lower edge of a projecting weathertight structure such as a floor, roof or deck. "Exposed" shall be below that 45° line. See figure 4.3(a) and (b).
- (5) Type 304 stainless steel is sufficient to comply with NZBC requirements, but may have surface rust. Type 316 may be used where appearance is a consideration but exceeds the requirements of the NZBC.
- (6) "Fabricated brackets" shall be made from 5 mm (minimum thickness) mild steel and shall be hot-dipped galvanized.

ULTIMATE BRICK TIE

ULTIMATE BRICK TIE - GALVANIZED



SIZE	PACK QTY	CODE
90mm*	250	BTIE90G
90mm*	500	BTIE90G500
115mm*	250	BTIE115G
115mm*	500	BTIE115G500

*Packs are supplied with T17 12g X 35mm Timber screws

FOR STEEL FRAMING

90mm*	250	BTIETK90G
90mm*	500	BTIETK90G500

*Packs are supplied with self drilling 12g x 35mm metal screws

ULTIMATE BRICK TIE - T316 STAINLESS STEEL



SIZE	PACK QTY	CODE
90mm*	250	BTIEX90T
90mm*	500	BTIEX90T500
115mm*	250	BTIEX115T

*Packs are supplied with T17 12g X 35mm Timber screws

Seismically tested for NZ brick home construction.

Brick ties are a critical element of brick veneer construction. The Ultimate Brick Tie has superior grip tension on all planes of movement, making it the ideal tie for use in New Zealand's highly seismic landscape.

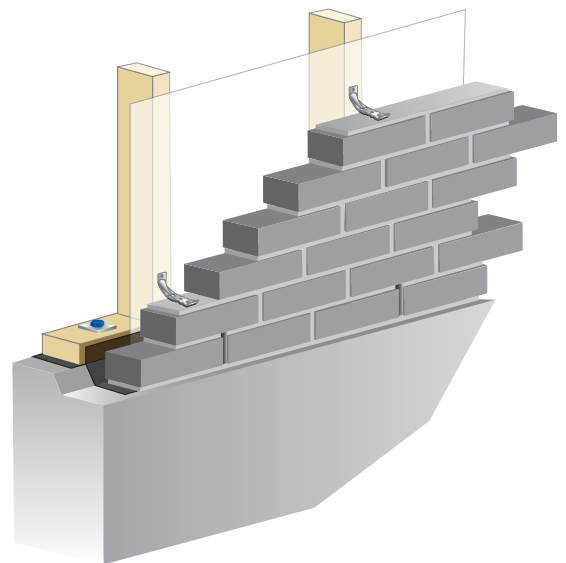

Galvanised Ultimate Brick Ties have a 70+ microns coating - 20% over the required standard.

50 Year durability warranty.

Rated EH - Earthquake Heavy. Clearly stamped as NZ standards require.

The only brick tie that meets **AS/NZS 2699.1:2000**

BRACING BRACKET

BRACING BRACKET KITS- GALVANISED



DESCRIPTION	PACK QTY	CODE
BAG	1 PAIR	BHBB
BUCKET*	10	BHBBSB10B

*Packs are supplied with T17 screws and Fortress Screw Bolts M10 x 127mm

Use as a bracing element in framing and timber joists.

M10 x 127mm screw bolt exceeds both minimum 15kN uplift strength into concrete and the 12kN uplift into timber joists. Screwbolt supplied in Hot dipped Galv. Eliminates the need of an additional coach screw into second story and/or timber sub floors.

Exceeds national standard: NZS 3604:2011.

Can be installed at any stage before wall lining.

One piece bracket for quick easy installation.

Standard market product



Fortress Bracing system



Using the Fortress M10 x 127mm Screw Bolt eliminates the risk of penetrating the concrete slab. Therefore eliminating the risk of moisture entering screw bolt hole.

External brace wall

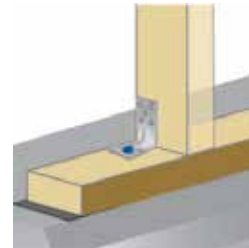

Internal brace wall

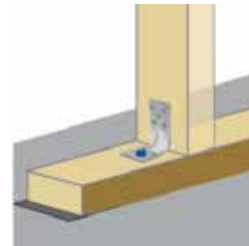

NAIL PLATES

SIZE	FINISH	PACK QTY	CODE
68 X 60mm	GALVANIZED	10	BHNP6860G
40 X 101mm	304 STAINLESS	10	BHNPX40101
67 X 127mm	304 STAINLESS	10	BHNPX67127

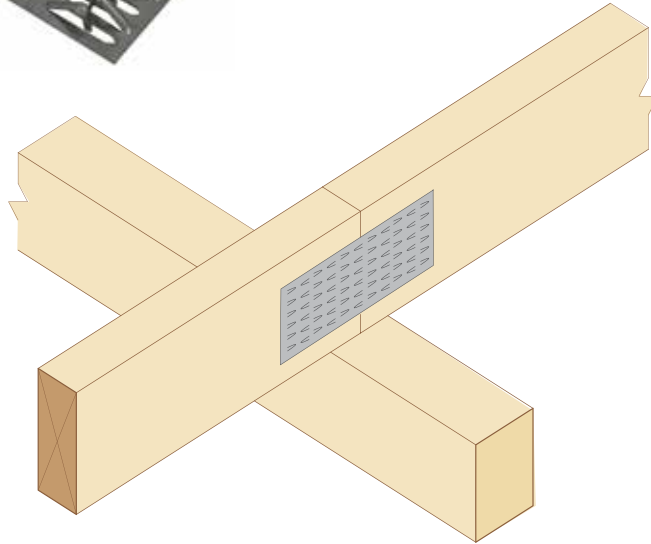

6kN PILE FIXING KIT - T304 STAINLESS STEEL

CONTAINS	QTY	CODE
T304 LEFT CLEATS	2	BHX6KN
T304 RIGHT CLEATS	2	
"C" NAILS	4	
4X90mm ANNULAR GROOVED NAILS	8	
4X45mm ANNULAR GROOVED NAILS	24	



Bearer attached to pile using 4 x 102mm straight C style nails, 2 applied at the face of the pile, 2 applied at the back and 4 x 90mm ring shanked nails skewed front and back and either side, underneath the pile into the bottom of the bearer.

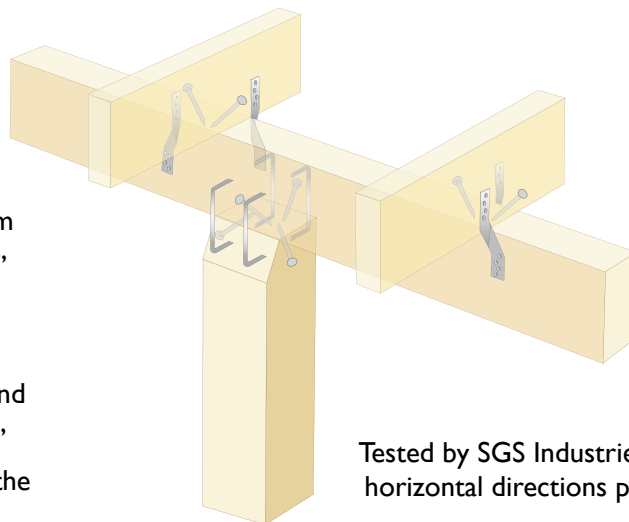

Joist to be attached to bearers either side of a pile using 2 x 160mm Fortress Joist Ties and 2 x 90mm nails skewed either side of the joist.

Tested by SGS Industries New Zealand to exceed 6kN in both horizontal directions parallel and perpendicular to the bearer.

12kN PILE FIXING KIT - T304 STAINLESS STEEL



CONTAINS	QTY	CODE
T304 LEFT CLEATS	4	BHX12KN
T304 RIGHT CLEATS	4	
T304 NAIL-ON PLATES	2	
4.0 X 90mm ANNULAR GROOVED NAILS	8	
4.0 X 45mm ANNULAR GROOVED NAILS	24	

Subfloor construction must be in accordance with NZS3604:2011

Lines of lateral support to floor joists as specified in 7.1.2.2 of the above standard shall be provided within 300mm of the ground floor, sub-floor lines and along other lines of the ground floor that contain bracing elements.

The fixings provided in this kit must be applied in accordance with the directions below.

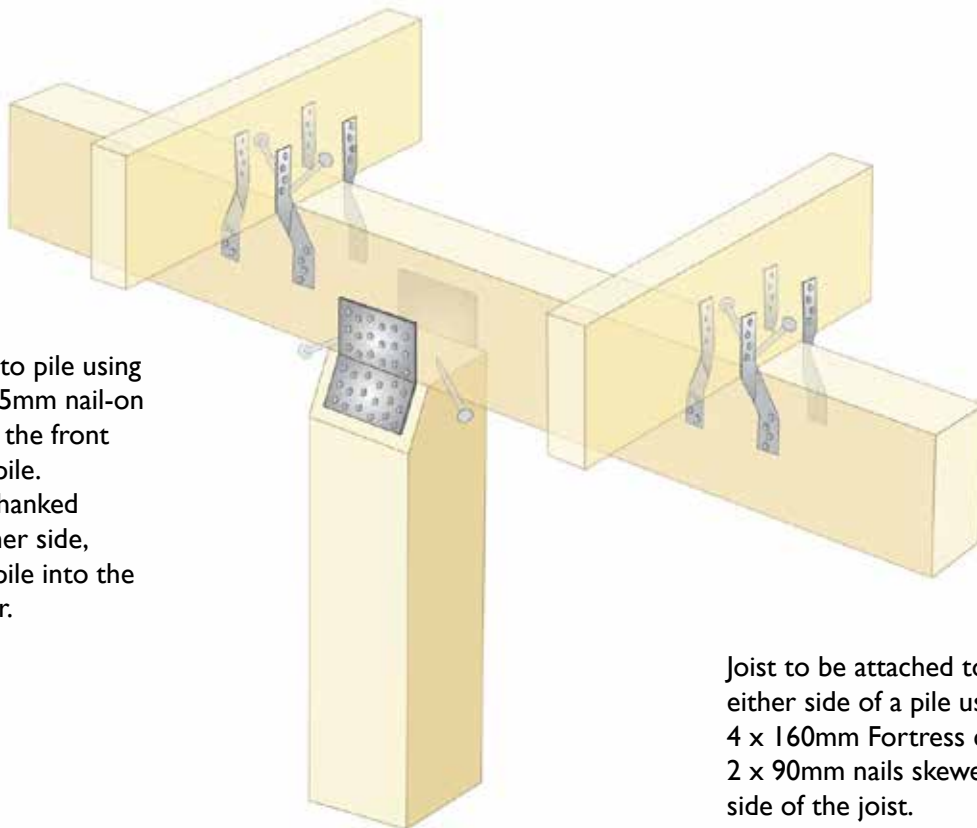

Bearer attached to pile using 2 x 160mm x 105mm nail-on plates applied to the front and back of the pile. 2 x 90mm ring shanked nails skewed either side, underneath the pile into the bottom of bearer.

Joist to be attached to bearers either side of a pile using 4 x 160mm Fortress cleats and 2 x 90mm nails skewed either side of the joist.

Tested by SGS Industries New Zealand to exceed 12kN in both horizontal directions parallel and perpendicular to the bearer.

CLEATS - T304 STAINLESS STEEL

DESCRIPTION	PACK QTY	CODE
160mm LONG - LEFT	20	BHCLXL
160mm LONG - RIGHT	20	BHCLXR

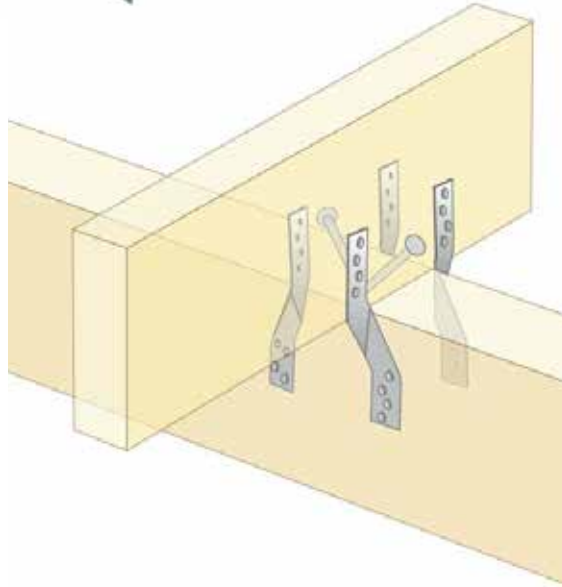

Z & C NAILS - GALVANISED

SIZE	PACK QTY	CODE
LEFT HAND "Z"	25	BHWDGL
RIGHT HAND "Z"	25	BHWDGR
STRAIGHT "C"	25	BHWDGS



Z & C NAILS - T304 STAINLESS STEEL

SIZE	PACK QTY	CODE
LEFT HAND "Z"	25	BHWDGXL
RIGHT HAND "Z"	25	BHWDGXR
STRAIGHT "C"	25	BHWDGXS



ANNULAR GROOVED FLAT HEAD NAILS - T304



SIZE	PACK QTY	CODE
3.3 x 30mm	500g	BHNX3330
3.3 x 45mm	500g	BHNX3345

SHEET BRACING STRAP

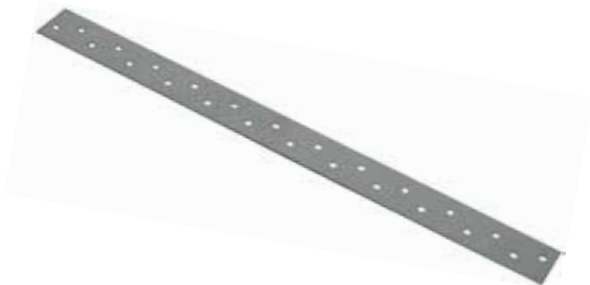

SIZE	FINISH	PACK QTY	CODE
300 x 25 x 1.0mm	GALVANISED	10	BHSB300G
400 x 25 x 1.0mm	GALVANISED	10	BHSB400G
600 x 25 x 1.0mm	GALVANISED	10	BHSB600G
300 x 25 x 1.0mm	STAINLESS STEEL	10	BHSBSX300
400 x 25 x 1.0mm	STAINLESS STEEL	10	BHSBSX400
600 x 25 x 1.0mm	STAINLESS STEEL	10	BHSBSX600

BRACE STRAPPING



SIZE	PACK QTY	CODE
25mm x 10m	10m COIL	BHBS2510
50mm x 15m	15m COIL	BHBS5015
50mm x 30m	30m COIL	BHBS5030
WITH TENSIONER		
25mm x 30m	30m COIL	BHBS2530
TENSIONERS		
25mm	10	BHBST25
50mm	5	BHBST50

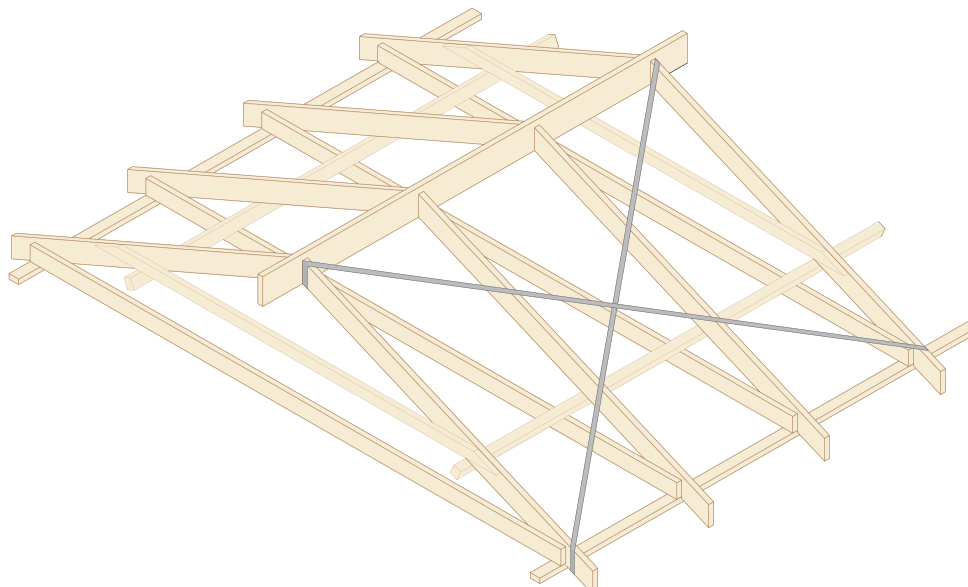

DIAGONAL CLEATS - GALVANISED



SIZE	PACK QTY	CODE
240mm LEFT	1	BHDCLG
240mm RIGHT	1	BHDCRG

BUILDING PAPER GRIPPERS



DESCRIPTION	PACK QTY	CODE
GALVANISED	50	BHGRIPPER

MULTI GRIPS



SIZE		PACK QTY	CODE
93mm	GALVANISED	50	BHMG93G
114mm	GALVANISED	50	BHMG114G
93mm	T304 STAINLESS	50	BHMGX93
114mm	T304 STAINLESS	50	BHMGX114
125mm	T304 STAINLESS	50	BHMGX125

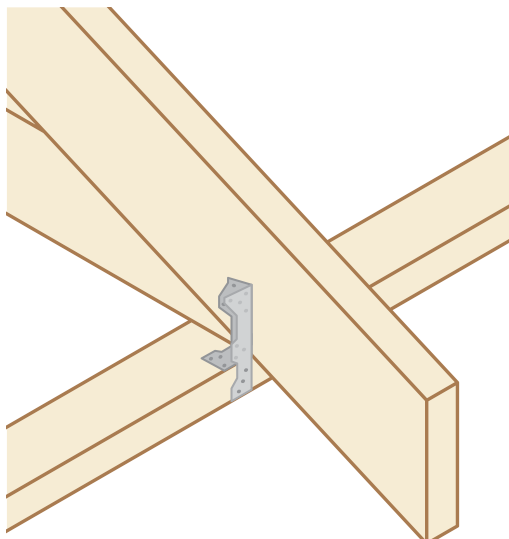

CT160 CLEATS - STAINLESS STEEL

SIZE	PACK QTY	CODE
160mm LEFT	20	BHCLXL
160mm RIGHT	20	BHCLXR



LH

CEILING HANGERS - GALVANISED

SIZE	PACK QTY	CODE
200mm LEFT	1	BHCHLG
200mm RIGHT	1	BHCHRG



LH

CYCLONE TIES - GALVANISED

SIZE	PACK QTY	CODE
400mm	1	BHCT400G
600mm	1	BHCT600G

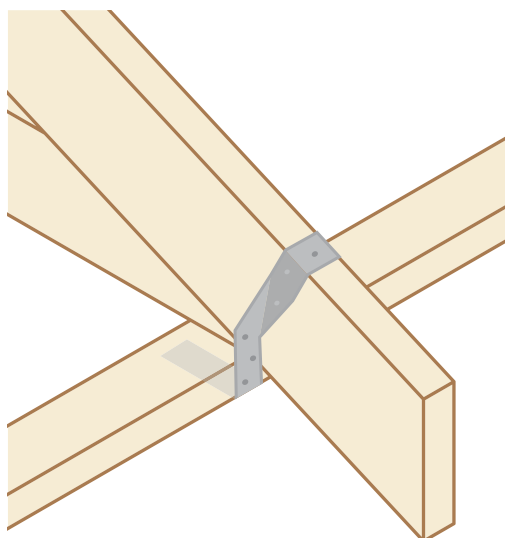

GIRT PLATES - GALVANISED



SIZE	PACK QTY	CODE
120mm	1	BHGPG

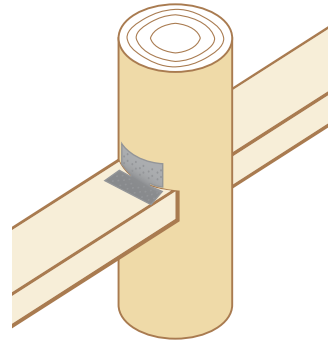

CPC L BRACKET - GALVANISED



SIZE	PACK QTY	CODE
47 X 40mm	25	BHLBRACKET47G
86 X 80mm	25	BHLBRACKET8680G
86 X 40mm	25	BHLBRACKET86G

16kN CPC TRUSS KIT



CONTAINS	QTY	CODE
CPC 86	2	BHCPC868016KN
3.15 X 30 GALV NAILS	16	
14g X 75mm T17 TIMBER SCREWS	8	

9kN CPC TRUSS KIT



CONTAINS	QTY	CODE
CPC 40	2	BHCPC86409KN
3.15 X 30 GALV NAILS	8	
14g X 75mm T17 TIMBER SCREWS	4	

STUD STRAP - GALVANISED

SIZE	PACK QTY	CODE
195mm	1	BHSS195G

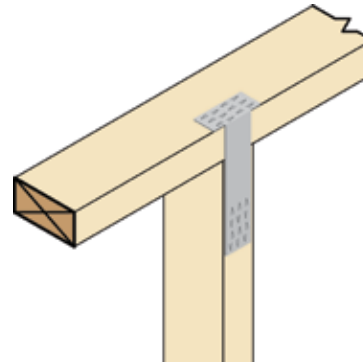

JOIST GRIPPA - STAINLESS STEEL

DESCRIPTION	PACK QTY	CODE
READY TO INSTALL*	20	BHJGBX20
READY TO INSTALL*	50	BHJGBX50



*INCLUDES: JOIST GRIPPA BRACKETS, T17 HEX SCREWS AND ANNULAR GROOVED NAILS FOR FULL INSTALLATION.



The Joist Grippa bracket is an alternative fixing solution to the current NZS3604 coach screw fixing of joists to boundary joists on timber decks where balustrades are required.

JOIST HANGERS - GALVANISED

SIZE	SUITABLE FOR	PACK QTY	CODE
47 x 95mm	GAUGE TIMBER	??	BHJH4795G
47 x 120mm	GAUGE TIMBER	25	BHJH47120G
47 x 180mm	GAUGE TIMBER	25	BHJH47180G
52 x 120mm	ROUGH SAWN	25	BHJH52120G
52 x 180mm	ROUGH SAWN	25	BHJH52180G
95 x 165mm	DOUBLE	??	BHJH95165G



JOIST HANGERS - STAINLESS STEEL

SIZE	PACK QTY	CODE
47 x 120mm	T304	25
47 x 180mm	T304	25
47 x 120mm	T316	25
47 x 180mm	T316	25



PRODUCT SUBSTITUTION.

Product Substitution – variations and building consent amendments.

Many substitute products can be accepted without formal amendments.

Variations to consented building work during a construction project is common. This statement has been prepared to clarify some minor misinterpretations with building code regulations and consultation in regards to product substitution. There have been limited situations on-site where variations to a specific product have been rejected due to insufficient compliance documentation supplied or misunderstandings around when substitution is allowed.

In many cases the building consent authority will have existing knowledge of acceptable substitute products and there will be no issue of compliance.

Variations to consented plans can be approved following a phone call to the building consent authority and with a detailed note made on consented plans by the building official. Significant variations to the consented construction plans will require the completion of Form 2- Application for project information memorandum and/or building consent. However it is unlikely Fortress builders hardware will require this application form.

The builder will notify the building official that a substitute product has been used. If the official is unfamiliar with the product, they can be referred by the builder to Fortress specification and product information guides.

All Fortress building hardware products are fully compliant with building code regulations and standards of performance and durability. All Fortress products are covered under a manufacturers guarantee when installed for the correct purpose. Always follow Fortress instruction manuals when provided.



The Best stainless steel hardwood decking screws.





Fortress carries a full range of fasteners to use with all our builders hardware.

See our Deck IT or T17 & SDS Screw catalogues for full range

- Double thread firmly embeds for a tight finish; reduces bowing of timbers.

- Unique thread cutting system offers fast fixing into hardwood timber decking.

- Positive Torx drive recess provides aesthetic finish.

- Square thread feature reduces resistance during installation.

- Raised counter-sunk head.



FORTRESS CODE	FORTRESS DESCRIPTION	COMPETITOR CODE	COMPETITOR CODE
STAINLESS STEEL			
BHX12KN	12KN PILE FIXING PACK S/S T304	12KNRFH	PBK12S
BHX6KN	6KN PILE FIXING PACK S/S T304		PBK6S
BHJHX47120	47 X 120 JOIST HANGER S/S T304	SSJH47120	MPFB45120/S
BHJHX47180	47 X 180 JOIST HANGER S/S T304	SSJH47180	MPFB45180/S
BHJHX47120T	47 X 120 JOIST HANGER S/S T316		
BHJHX47180T	47 X 180 JOIST HANGER S/S T316		
BHMGX114	114MM LONG MULTI GRIP S/S T304		
BNMGX125	125MM LONG MULTI GRIP S/S T304		
BHMGX93	93MM LONG MULTI GRIP S/S T304		
BHSBSX300	300 X 25 SHEET BRACING STRAP S/S T304	SSSBS3	SBS300/S
BHSBSX400	400 X 25 SHEET BRACING STRAP S/S T304	SSSBS4	SBS400/S
BHSBSX600	600 X 25 SHEET BRACING STRAP S/S T304	SSSBS6	SBS600/S
BHWDXL	102MM LEFT HAND WIRE DOGS S/S T304	SSWDLH	MPZL/S
BHWDXR	102MM RIGHT HAND WIRE DOGS S/S T304	SSWDRH	MPZR/S
BHWDXS	102MM STRAIGHT WIRE DOGS S/S T304	SSWDS	MPZU/S
BHNX3345	3.3 X 45 FLAT ANNULAR GROOVE S/S NAILS - BAG 500G	PNS45500	
BHNX3330	3.3 X 30 FLAT ANNULAR GROOVE S/S NAILS - BAG 500G	PNS30500	CSB030135
BHNPX40101	40 X 101 S/S NAIL PLATE (KNUCKLE PLATE)		
BHNPX67127	67 X 127 S/S NAIL PLATE (KNUCKLE PLATE)		
GALVANISED			
BHJH47120G	47 X 120 JOIST HANGER GALV	JH47120	MPFB45120
BHJH47180G	47 X 180 JOIST HANGER GALV	JH47190	MPFB45180
BHJH52120G	52 X 120 JOIST HANGER GALV	JH52120	MPFB52124
BHJH52180G	52 X 180 JOIST HANGER GALV	JH52180	MPFB52174
BHJH95165G	95 X 165 JOIST HANGERS GALV	JH95	FB94/152
BHN31530G	3.15MM X 30MM FLAT HD NAILS GALV 500G	PN30500	GBC030315
BHMG114G	114MM MULTIGRIP GALV		
BHMG93G	93MM MULTIGRIP GALV		
BHLBRACKET47G	47 X 40 CONCEALED PURLIN CLEAT (CPC L BRACKET)	CPC40S	
BHLBRACKET86G	86 X 40 CONCEALED PURLIN CLEAT (CPC L BRACKET)	CPC40	NPPC4
BHLBRACKET8680G	86 X 80 CONCEALED PURLIN CLEAT (CPC L BRACKET)	CPC80	NPPC8
BHSB300G	300 X 25 SHEET BRACING STRAP	SBS3100	SBS300
BHSB400G	400 X 25 SHEET BRACING STRAP	SBS4100	SBS400
BHSB600G	600 X 25 SHEET BRACING STRAP	SBS6100	SBS600
BHWDGL	102MM LEFT HAND Z NAILS GALV (25)	WDLHS	MPZL
BHWDGR	102MM RIGHT HAND Z NAILS GALV (25)	WDRHS	MPZR
BHWDGS	102MM STRAIGHT Z NAILS GALV (25)	WDSS	MPZU
BHCHLG	200MM LEFT CEILING HANGER GALV	CT200LH	CPH190LH
BHCHRG	200MM RIGHT CEILING HANGER GALV	CT200RH	CPH190RH
BHBB	BRACING BRACKET WITH PLATES + SCREWS GALV (1 PAIR)	GIBHBRAC	PBA
BHBSB10	BRACING BRACKET PLATES S/BOLTS SCREWS GALV (1 PAIR)	GIBHBRACWB	
BHBS2510	25MM X 10M BRACE STRAPPING GALV	SB10	SB10
BHBS2530	25MM X 30M BRACE STRAPPING + 5 TENSIONERS GALV	SB30T	SB30T
BHBS5015	50MM X 15M BRACE STRAPPING GALV	MB15	SBI/15
BHBST25	25MM BRACE STRAPPING TENSIONER (PACK OF 10)	SBTENS per 25	SBT
BHBST50	50MM BRACE STRAPPING TENSIONER (PACK OF 5)	MBTENS	SBI/T
BHCPC86409KN	9KN CPC TRUSS KIT	9KNTP	
BHCPC868016KN	16KN CPC TRUSS KIT	16KNTP	
BHCT400G	400MM CYCLONE TIE GALV	CT400	MPQHS4
BHCT600G	600MM CYCLONE TIE GALV	CT600	MPQHS6
BHGPG	120MM 90DEG GIRT PLATE GALV	GIRTPLATE	NPP2G
BHGRIPPER	HAMMER ON SNAP OFF CONNECTORS (STRIP OF 5) GALV	LG	SF1
BHDCLG	240MM LEFT DIAGONAL CLEAT GALV	N21LH	NPDL
BHDCRG	240MM RIGHT DIAGONAL CLEAT GALV	N21RH	NPDR
BHSS195G	STUD STRAP 195MM GALV	BHSS195G	SST(STS25)
BHNP6046G	NAIL PLATE 60MM X 46MM GALV		
BHNP6846G	NAIL PLATE 68MM X 46MM GALV		
BHNP6860G	NAIL PLATE 68MM X 60MM GALV		
BHNP7676G	NAIL PLATE 76MM X 76MM GALV		
BHJGBX20	JOIST GRIPPA 20 PACK		
BHJGBX50	JOIST GRIPPA 50 PACK		



100% NZ Owned & Operated